



# **MOTORTRONICS**

*Solid State AC Motor Control*

## **ME2 Series Micro AC Drives**

---

### **INSTALLATION & START-UP MANUAL**

**REV3  
9081101MN**

# Motortronics ME2 Series Micro AC Drives

Thank you for purchasing this Motortronics **ME2 Series** variable frequency AC drive. When properly installed, operated and maintained, the ME2 will provide a lifetime of reliable operation. It is mandatory that the person who operates, inspects, and maintains this equipment thoroughly reads and understands this manual. This will insure safe and reliable operation of the controller.

This unit has been put through demanding tests at the factory prior to shipment. Before unpacking check the following:

- Verify that the model number on the box matches your purchase order.
- Inspect for possible shipping damage (if damaged, notify the freight carrier and file a claim within 15 days of receipt).

After unpacking, please check the following:

- Verify that the label specifications match your application requirement.
- Check all electrical connections and screws. Verify that there is no visible damage to any of the components.



**Warning! Do not service equipment with voltage applied! Unit can be a source of fatal electrical shock! To avoid shock hazard, disconnect main power and wait until the LED on the main control board goes out before working on the control. Warning labels (not supplied) must be attached to terminals, enclosure and control panel.**

**Unit does not provide overspeed protection or incorporate current limiting control.**

**To obtain optimum operation from your *ME2 Series* drive, it is strongly recommended that this manual is read and understood.**

## Table of Contents

<b>Chapter 1 General Information .....</b>	<b>1</b>
1.1 Introduction	
1.2 Specifications	
1.3 Mounting Dimensions/ Terminal Block Location	
<b>Chapter 2 Power and Control Wiring .....</b>	<b>5</b>
2.1 Power and Control Wiring	
2.2 Wiring Diagram	
2.2.1 Power Terminal Block ( TM1 )	
2.2.2 Control Terminal Block ( TM2)	
2.2.3 External Control Signal Selection ( SW1 )	
<b>Chapter 3 Keypad Operation and Programming .....</b>	<b>10</b>
3.1 Keypad Operation	
3.2 Easy Programming	
3.3 List of Parameters	
3.4 Parameter Function Description	
<b>Chapter 4 Fault Codes .....</b>	<b>25</b>
4.1 Failure or Trip which cannot be reset by Reset Key	
4.2 Failure or Trip which can be reset by Reset Key but cannot be Auto Reset	
4.3 Failure or Trip which can be Auto Reset or reset by Reset Key	
4.4 Operational Stop Indications	
4.5 Operation Error Indications	
<b>Chapter 5 Other Information .....</b>	<b>29</b>
5.1 Selecting AC Line/Load Reactors	
5.2 Record of Drive Settings	



## Chapter 1 - General Information

## 1.1- Introduction

The Motortronics **ME2 Series** is a high performance general-purpose micro AC drive that incorporates a high efficiency Pulse Width Modulated (PWM) design and IPM technology. The output closely approximates a sinusoidal current waveform to allow variable speed control of any conventional squirrel cage AC induction motor.

## 1.2 - Specifications

Input Voltage 50/60 Hz ( $\pm 5\%$ )	1P2 thru 101: Single phase							
	110 ~ 120V (-15% $\pm 10\%$ )							
	2P2 thru 203: Single phase							
	200 ~ 240V (+10%/-15%)							
Output Voltage	401 thru 403: Three phase 380 ~ 460V							
Control Method	Sinusoidal wave PWM control (PNP type 12 - 24V)							
Ratings	Model Number (ME2-XXX-M)							
	1P2	1P5	101	2P2	2P5	201	202	203
Motor KW	0.2	0.4	0.75	0.2	0.4	0.75	1.5	2.2
Motor HP	1/4	1/2	1	1/4	1/2	1	2	3
Current A	1.4	2.3	4.2	1.4	2.3	4.2	7.5	10.5
Capacity KVA	0.53	0.88	1.6	0.53	0.88	1.6	2.9	4.0
Weight lbs	1.5	1.5	1.5	1.6	1.7	1.8	3.8	3.8
Ratings	Model Number (ME2-XXX-M)							
	401	402	403					
Motor KW	0.75	1.5	2.2					
Motor HP	1	2	3					
Current A	2.3	3.8	5.2					
Capacity KVA	1.7	2.9	4					
Weight lbs	3.5	3.5	3.6					

Me2 Series

-1-

## 1.2 - Specifications

Approvals	UL, cUL, CE
Mounting	Direct or optional DIN rail mount (for $\leq 1$ HP drives)
Digital Display	Indicates, frequency, parameter selection, fault record

### 1.2.1 - Frequency Control

Frequency Control	Range	1 - 200 Hz
	Resolution	Digital: 0.1 Hz (0-99.9Hz) 1 Hz (100 -120 Hz) Analog: 1 Hz (60Hz)
	Setting Signal	Digital Keypad; 0-10VDC, 0-20mA, 10K Pot
	Limit	Frequency upper/lower limit
	Carrier Frequency	4 ~ 16 kHz

### 1.2.2 - Control Characteristics

### 1.2.3 - Protective Functions

Protective Function	Overload	150% for 1 minute
	Over-voltage	DC-bus voltage > 410 V
	Under-voltage	DC-bus voltage < 200 V
	Momentary Power Loss	0-2 seconds (can be restarted via speed search)
	Stall prevention	During accel/decel/constant speed
	Output short circuit	Provided by electronic circuit
	Ground fault	Provided by electronic circuit during start-up and run
	Other protection	Heatsink fin overtemp, current limit

### 1.2.4 - Environmental Specifications

Ambient Temperature	- 10 to + 40° C (14° to 104° F)
Humidity	≤ 95% relative, non-condensing
Vibration	Under 1G
EMC	Class A filter standard in all 200 volt units rated 1/4 thru 1 HP; Optional Class B for all other units
Enclosure	Panel Mount / IP20

*Me2 Series*

-3-

### 1.3 - Mounting Dimensions

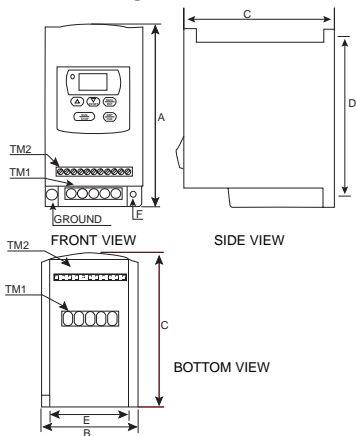

ME2 Dimensions						
Model	Overall Dimensions			Mounting Dimensions		
	A	B	C	D	E	F
ME2-1P2-M	5.2	2.8	4.6	4.6	2.4	0.18
ME2-1P5-M						
ME2-2P2-M						
ME2-2P5-M						
ME2-201-M	5.63	4.65	6.76	5.0	4.25	0.18
ME2-202-M						
ME2-203-M						

Me2 Series

-4-

## Chapter 2 - Power and Control Wiring

### 2.1 - Power and Control Wiring

This chapter deals with recommended power wiring practices for the **ME2 Series** AC drive. Remember, you must always conform to the National Electrical Code (NEC) and any applicable local codes. Always make sure the keypad is off, the LEDs are off, and the DC bus is discharged before adding or changing any wiring.

**Warning!** This section involves working with potentially lethal voltage levels! Caution must be used to prevent personal harm. Do not service equipment with voltage applied! To avoid shock hazard, disconnect main power and wait until the LED on the main control board goes out before working on the control. Warning labels (not supplied) must be attached to terminals, enclosure and control panel.



- **DO NOT** touch any circuit components while AC power is on or immediately after the main AC power is disconnected from the unit. Wait until the LED on the control board goes out.
- **DO NOT** make any connections to the drive before the unit is disconnected from the AC power. Failure to adhere to this warning could result in serious or lethal injury.
- Only use in a pollution degree 2 macro--environment or equivalent.

- **Never connect the input power wiring to the drive terminals T1, T2, or T3.**
- **Always use UL/CSA approved wire and ring lugs.**
- **Always make a positive ground termination to the Earth terminal of the drive.**
- **Use copper conductors only and size field wiring based upon 75° wire only.**

Model Number	Maximum Input Fuse (Time Delay)	Maximum Input Circuit Breaker (Amps)	Power Wiring	Control Wiring	Copper Ground Wiring
ME2-1P2	8	10	14-12 AWG	22-18 AWG	14 AWG
ME2-1P5	12	20			
ME2-2P2	4.5	10			
ME2-2P5	8	10			
ME2-201	12	20			12 AWG
ME2-202	20	30	12-10 AWG		10 AWG
ME2-203	30	40			

**Notes:**

1. 240 VAC units are suitable for use on a circuit capable of delivering not more than 5000 RMS symmetrical amperes, 240 Volts maximum.
2. Always ensure that values used conform to NEC and all applicable local codes.

Note: Keypad operator cannot be removed.

**Me2 Series**

-6-

## 2.2 - Me2 Wiring Diagram

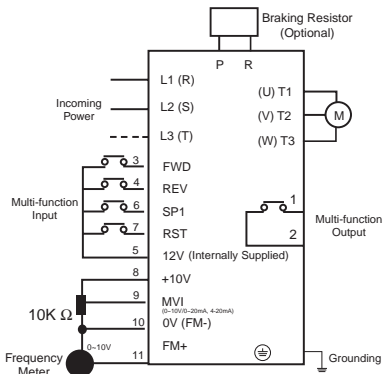

\*NOTE: L3(T) is only used on ME-202 and ME-203

### 2.2.1- Power Terminal Block (TM1)

Notes:

1. Tightening torque for TM1 is 1 lbs-ft or 12 lbs-in.
2. Use copper conductors only. Size field wiring based on 75°C wire only.
3. Wire voltage rating must be a minimum of 300V.
4. Ratings of the terminal block (TM1) are 300V, 15A

Symbol	Function Description
L1 (R)	AC power source input
L2 (S)	
L3 (T)	
P	External braking resistor (only for Me2-202/203/401/402/403)
R	
T1 (U)	Drive output to the motor
T2 (V)	
T3 (W)	

Me2 Series

-7-

## 2.2.2- Control Terminal Block ( TM2 )

Function Description			
1	Programmable output (Fn21)		
2	Rated 250VAC/30VDC, 1A		
3	FWD	Operation control terminals (refer to Fn03)	
4	REV		
5	+12V	Common point of terminals 3 / 4 / 6 / 7	
6	SP1	Multifunction input terminals (refer to Fn20)	
7	RESET	Multifunction input terminal 2 (Fn20)	
8	0V (FM-)	+10V	Power terminal of potentiometer (High side of potentiometer)
9		Analog input point	Analog frequency signal input terminal (wiper of potentiometer or positive terminal of 0~10V / 4~20mA / 0~20mA)
10		Analog common point	Analog signal common point (Low side of potentiometer or negative terminal of 0~10V / 4~20mA / 0~20mA)
11	FM+	Analog output positive connection point	Multifunction analog output terminal Output terminal signal is 0~10VDC

### Notes:

1. Tightening torque for TM2 is 0.42 lbs-ft or 5.03 lbs-in.
2. Use copper conductors only. Size field wiring based on 75°C wire only.
3. Wire voltage rating must be a minimum of 300V.
4. Control wiring should not run in the same conduit or raceway with power or motor wiring.

Me2 Series

-8-

## 2.2.3- External Control Signal ( SW1 )

SW1 is located in a compartment on the side of the AC drive.

Switch	External Signal Type
I V	1 2 3
I V	1 2 3

0~20mA analog signal ( When Fn11 is set to 1 )

4~20mA analog signal ( When Fn11 is set to 2 )

0~10 VDC analog signal ( When Fn11 is set to 1 )

Remove cover to reveal switch

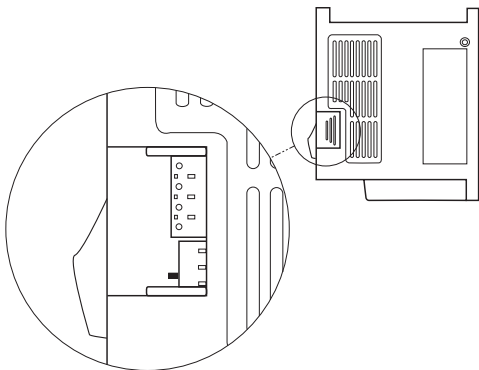

Me2 Series

-9-

**Chapter 3 - Keypad Operation and Programming****3.1 - Keypad Operation**

Refer to this section if the keypad will be used to control the drive and if no external control connections are required. This section can also be used when testing the drive without control connections.

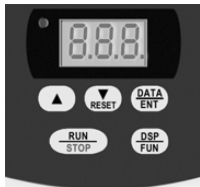

Note: Keypad operator cannot be removed.

**3.2 - Easy Programming**

The **ME2 Series** has two basic loops:

**Operation Loop-** changes frequency to increase/decrease motor speed

**Programming Loop-** changes function settings

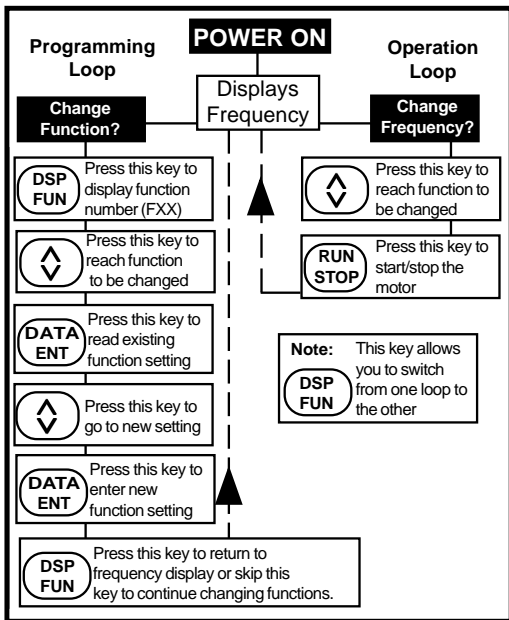

### 3.3- List of Parameters

Function	FN	Function Description	Unit	Range	Factory Setting
	0	Factory Adjustment			000
Accel/Decel time	1	Acceleration time [Notes: 1, 2]	0.1 sec	0.1-999 S	5.0 S
	2	Deceleration time [Notes: 1, 2]	0.1 sec	0.1-999 S	5.0 S
Operation mode	3	0: Forward / Stop, Stop / Reverse 1: Run / Stop, Reverse / Forward	1	0-1	000
Motor rotation direction	4	0: Forward 1: Reverse [Note:1]	1	0-1	000
V/F pattern	5	V/F pattern setting [Notes: 3, 4]	1	1-6	4
Frequency upper/lower limit	6	Frequency upper limit [Notes: 2, 3, 4]	0.1Hz	0.0-200 Hz	60 Hz
	7	Frequency lower limit [Note: 2]			000
SP1 frequency	8	SP1 frequency [Note: 2]			10 Hz
JOG frequency	9	JOG frequency [Note: 2]		6 Hz	
Operation Control	10	0: Keypad 1: External control	1	0-1	000
Frequency Control	11	0: Keypad 1: 0 - 10V, 4 - 20mA, 10K pot (no offset) 2: 2 - 10V, 4 - 20mA (with 20% offset)	1	0-2	000

#### Notes:

1. Can be changed during running mode.
2. If the setting is between 0.1 and 1, the display increments in 0.1 units. If the setting is equal to or greater than 1, the display increments in units of 1.
3. Refer to Fn25.
4. Factory set default settings depend on Fn25 programming.

### 3.3- List of Parameters (continued)

Function	FN	Function Description	Unit	Range	Factory Setting
Carrier frequency	12	Carrier frequency setting	1	1-10	5
Torque compensation	13	Torque compensation gain [Note: 1]	0.1%	0.0-10.0%	000
Stopping mode	14	0:Decelerate to stop 1: Coast to stop	1	0-1	000
DC Braking Setting	15	DC braking time	0.1 sec	0.0-25.5 S	0.5 S
	16	DC braking injection frequency	0.1 Hz	1-10 Hz	1.5 Hz
	17	DC braking level	0.10%	0.0-20.0%	8.0%
Electronic Thermal Overload	18	Based on drive rated current	1%	0-200%	100%
Programmable Inputs	19	Multifunction Input (TM1)	1: Jog 2: SP1 3: Emergency Stop 4: External Base Block 5: Reset 6: SP2		2
	20	Multifunction Input (TM2)			5

#### Notes:

1. Can be changed during running mode.
2. If the setting is between 0.1 and 1, the display increments in 0.1 units. If the setting is equal to or greater than 1, the display increments in units of 1.
3. Refer to Fn25.
4. Factory set default settings depend on Fn25 programming.

### 3.3- List of Parameters (continued)

Function	FN	Function Description	Unit	Range	Factory Setting
Programmable Output	21	Multifunction Output	1: Running 2: At set speed 3: Fault		3
Reverse Mode Lockout	22	0: REV run enabled 1: REV disabled	1	0~1	000
Momentary Power Loss Restart	23	0: Enabled 1: Disabled	1	0~1	000
Auto Restart	24	Number of auto-restart times	1	0~5	000
Factory Setting	25	010: Constants initialized to 50 Hz system 020: Constants initialized to 60 Hz system			000
SP2 Frequency	26	SP2 Frequency [Note: 2]	0.1 Hz	0.0~200	20
SP3 Frequency	27	SP3 Frequency [Note: 2]	0.1 Hz	0.0~200	30
	28	Reserved for future use			
Software version	29	CPU program version			1.8
Fault History	30	Last 3 faults in memory			

#### Notes:

1. Can be adjusted during running mode.
2. If the setting is between 0.1 and 1, the display increments in 0.1 units. If the setting is equal to or greater than 1, the display increments in units of 1.
3. Refer to Fn25.
4. Factory set default settings depend on Fn25 programming.

### 3.4 - Parameter Function Description

**Fn00** Factory set. Do not change.

**Fn01** - Acceleration time

Factory Setting = 5 seconds; Range = 0.1 ~ 999 sec

**Fn02** - Deceleration time

Factory Setting = 5 seconds; Range = 0.1 ~ 999 sec

1. Acceleration/deceleration time calculation formula:

$$\text{Acceleration time} = \frac{\text{Fn01} \times \text{Setting Frequency}}{60\text{Hz}}$$

$$\text{Deceleration time} = \frac{\text{Fn02} \times \text{Setting Frequency}}{60\text{Hz}}$$

**Fn03** - Operation mode selection - Factory Setting = 000

Range = 0 : Forward / Stop , Reverse / Stop

= 1 : Run / Stop , Forward / Reverse

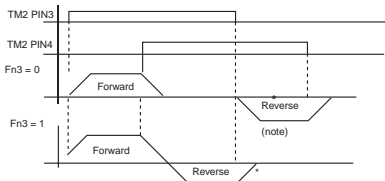
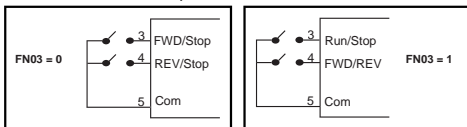

Note: Fn03 active only when Fn10 = 1 (external control)

**\*Reverse command is ignored when Fn22 = 1**

Me2 Series

-15-

## Fn04 - Motor rotation direction

**Factory Setting = 0**

**Range = 0** : forward

**= 1** : reverse

Note: When Fn22 = 1 : (Reverse disabled),

Fn04 cannot = 1. Keypad indication will display "LOC".

## Fn05 - V/F pattern

**Factory Setting = 4; Range = 1- 6**

Select one of six fixed V/F patterns :

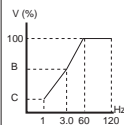
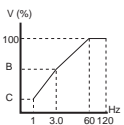
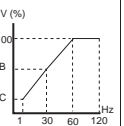
Application	General Application	High starting torque	Variable torque
Fn5 Setting	4	5	6
60 Hz V/F pattern			

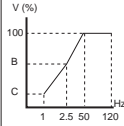
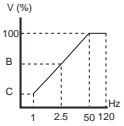
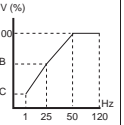
Application	General Application	High starting torque	Variable torque
Fn5 Setting	1	2	3
50 Hz V/F pattern			

Setting		Voltage%	
60Hz	50Hz	B	C
4	1	10%	80%
5	2	15%	10%
6	3	25%	7.70%

**Me2 Series**

-16-

### **Fn06 - Frequency upper limit**

**Factory Setting = 60Hz; Range = 0.0 ~ 200Hz**

### **Fn07 - Frequency lower limit**

**Factory Setting = 0.0; Range = 0 ~ 200 Hz**

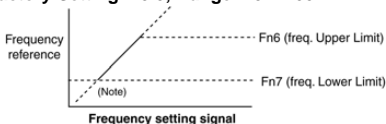

- Notes:
1. If Fn07 = 0 Hz, and the frequency is equal to 0Hz, the drive will stop at 0 speed.
  2. If Fn07 > 0 Hz, and the frequency is less than or equal to Fn07, the drive output will = Fn07.

### **Fn08 - SP1 frequency**

**Factory Setting = 10 Hz; Range = 0 ~ 200 Hz**

### **Fn09 - Jog frequency**

**Factory Setting = 6 Hz; Range = 0 ~ 200 Hz**

1. When Fn19 or Fn20 = 2 and multifunction input terminal is on, the drive will operate at SP1 frequency (Fn08)
2. When Fn19 or Fn20 = 1 and multifunction input terminal is on, the drive will operate at Jog frequency (Fn09)
3. The priority of using frequency reference is : Jog > SP1 > Keypad setting or external control signal

### **Fn10 - Operation Control**

**Factory Setting = 0**

**Range = 0** : Keypad operated

**= 1** : External control operated (emergency stop on the keypad is still active)

## Fn11 - Frequency control

**Factory Setting = 0**

**Range = 0** :Frequency reference is set via the keypad

**= 1** :Frequency reference is set via the potentiometer or analog signal on TM2 with no offset ( 0 ~ 10V / 0 - 20mA )

**= 2** :Frequency reference is set via the potentiometer or analog signal on TM2 with 20% offset (4-20mA )

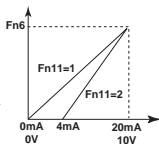

Note: When Jog frequency or SP1 frequency is switched on, the frequency is set via the Jog or SP1 speed. The arrow buttons on the keypad are disabled during acceleration /deceleration modes and when the multi-function terminal is active. Original settings will be restored after Jog or SP1 connection is OFF. **Ensure correct selection of SW1 (refer to 2.2.3).**

## Fn12 - Carrier frequency

**Factory Setting = 5; Range = 1 ~ 10 (4 ~ 16 kHz)**

Although IGBT type drives can provide low noise under normal operation, it is possible that the high carrier frequency may interfere with external electronic components (or other drives) or even cause vibration in the motor. Adjusting the carrier frequency can eliminate these problems.

FN12	Carrier Frequency	FN12	Carrier Frequency
1	4 kHz	6	10 kHz
2	5 kHz	7	12 kHz
3	6 kHz	8	14.4 kHz
4	7.2 kHz	9	15 kHz
5	8 kHz	10	16 kHz

Me2 Series

-18-

### **Fn13 - Torque compensation gain**

**Factory Setting = 0; Range = 0 ~ 10 %**

Drive output will be the B and C voltage points on the V/F pattern (refer to Fn05) plus the Fn13 setting. This setting will enhance the output torque. Note: When Fn13 = 0, the torque boost function is disabled.

### **Fn14 - Stopping mode**

**Factory Setting = 0**

**Range = 0 : Deceleration to stop**  
**= 1 : Coast to stop**

#### **If Fn14 = 0**

When the drive receives the stop command, it decelerates to the frequency set point of Fn16. The DC braking will start at the level set in Fn17. After the time duration (set in Fn15), the drive will stop.

#### **If Fn14 = 1**

The drive output stops immediately after receiving a stop command. The motor will enter a free running state and coast to a stop.

### **Fn15 - DC braking time**

**Factory Setting = 0.5; Range = 0 ~ 25.5 seconds**

### **Fn16 - DC braking starting frequency**

**Factory Setting = 1.5; Range = 1 ~ 10 Hz**

### **Fn17 - DC braking level**

**Factory Setting = 8.0; Range = 0 ~ 20 %**

## **Fn18 - Electronic Thermal Overload Factory Setting = 100; Range = 0 ~ 200 %**

### **1. Function of the electronic thermal overload protecting the motor**

1. Motor rated current = Drive rated current x Fn18 or  
Fn18 = Motor rated current / drive rated current

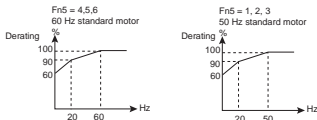

2. When the load is within 100% of the motor rated current, the drive will operate continuously. When the load reaches 150% of the motor rated current, the drive will trip within 1 minute.
3. After the electronic thermal overload is activated, the drive output is shut off immediately. OL1 will flash on the keypad. To resume operation, push the RESET button or activate the external reset terminal.
4. When operating at low speeds, the motor's heat dissipation capability is reduced. The electronic thermal overload activation level is also reduced. To ensure proper motor protection, choose an appropriate Fn05 setting.

### **2. Function of the electronic thermal overload protecting the drive**

1. When the load is within 103% of the drive rated current, the drive will operate continuously. When the load reaches 150% of the rated current of the drive, the drive will trip within 1 minute.

2. After activation of the drive's electronic thermal overload, the drive output shuts off immediately. OL2 will flash on the keypad. To resume operation, push the RESET button on the keypad or activate the external reset terminal.

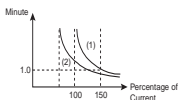

### **Fn19 - Multifunction input (TM2 - Pin 6)**

**Factory Setting = 2; Range = 1 ~ 6**

### **Fn20 - Multifunction input (TM2 - Pin 7)**

**Factory Setting = 5; Range = 1 ~ 6**

**1. Fn19, Fn20 = 1 : JOG**

**2. Fn19, Fn20 = 2 or 6 : Preset Speed Control**

Fn Setting	SP1 Terminal	Reset Terminal	Output Frequency
Fn 19 = 2 Fn 20 = 6	ON	OFF	FN 08 (SP1)
	OFF	ON	Fn 26 (SP2)
	ON	ON	Fn 27 (SP3)
Fn 19 = 6 Fn 20 = 2	ON	OFF	Fn 26 (SP2)
	OFF	ON	FN 08 (SP1)
	ON	ON	Fn 27 (SP3)

### **3. Fn19, Fn20 = 3 : External emergency stop signal**

When the external emergency stop signal is activated, the drive decelerates to a stop (ignoring the setting in Fn14). Keypad flashes E.S. after stop. When the emergency stop signal is deactivated, turn the RUN switch OFF and then ON again (if Fn10 = 1) or push the RUN key (if Fn10 = 0). The drive will resume operation and restart. If the emergency stop signal is removed before the drive stops, it will still execute emergency stop.

### **4. Fn19, Fn20 = 4 : External Base Block (immediate shut off)**

When the external base block signal is activated, the

*Me2 Series*

-21-

drive output immediately shuts off (ignoring the setting in Fn14). Keypad will flash b.b. after stop. After the base block signal is deactivated, turn the RUN switch OFF and then ON again (if Fn10 = 1) or push the RUN key (if Fn10 = 0). The drive will restart from the starting frequency.

#### **5. Fn19, Fn20 = 5 : Reset when drive is in fault condition**

#### **Fn21 - Multi-function output**

**Factory Setting = 3**

**Range= 1 : Run mode signal**  
**= 2 : At frequency signal**  
**= 3 : Fault signal**

#### **Fn22 - Reverse mode lockout**

**Factory Setting = 0**

**Range= 0 : REV command enabled**  
**= 1 : REV command disabled**

Note: When Fn04 is set to 1 (reverse), Fn22 cannot be set to 1. Keypad will display "LOC". Fn04 must be changed to 0 setting (forward) before Fn22 can be set to 1.

#### **Fn23 - Restart after momentary power loss**

**Factory Setting = 0**

**Range= 0 : Restart enabled**  
**= 1 : Restart disabled**

1. When AC power temporarily drops below the low voltage protection level the drive will stop immediately. If the power source returns within 2 seconds, the drive can restart via speed search (start searching from the previous operating frequency) or fault, displaying "LV-C".
2. When Fn23 = 0, if the temporary power loss is less than 2 seconds, the drive will resume operation via speed search 0.5 seconds after power returns. Fn24 does not

limit the number of restarts. If the temporary power loss is longer than 2 seconds, automatic restart will be determined by the setting of Fn24.

3. When Fn23 = 1, the drive will stop immediately after the temporary power loss and display "LV-C" on the keypad. The drive will not restart automatically. (Not controlled by Fn24)

### **Fn24 - Number of Auto-restart times**

**Factory Setting = 0; Range = 0 ~ 5**

1. When Fn24 = 0, the drive will not automatically restart if the power loss period is longer than 2 seconds.
2. When Fn24 > 0, the drive will resume operation via speed search 0.5 secs after power returns. The drive will accelerate or decelerate to the frequency setting.
3. When the drive is set to decelerate to stop (Fn14) or DC braking (Fn17) the transient restart procedure is not performed.
4. When either of the following occur, the auto-restart counter will be reset:
  1. No additional faults (during operation or stop) occur within 10 minutes of restart.
  2. RESET is pressed or external RESET is activated.

### **Fn25 - Factory setting - Factory Setting = 000**

**Range= 010 : Constants set for 50Hz system**

**= 020 : Constants set for 60Hz system**

1. When Fn25 is set to 010, all parameters are restored to settings for 50Hz operation. The settings of Fn05 and Fn06 are reset to 1 and 50 respectively. Fn25 is restored back to 000 after the reset process is complete.
2. When Fn25 is set to 020, all parameters are restored to the original factory settings for 60Hz operation. The

settings of Fn05 and Fn06 are reset to 4 and 60 respectively. Fn25 is restored back to 000 after the reset process is complete.

### **Fn26 - SP2 Frequency**

**Factory Setting = 20 Hz; Range = 0.0 ~ 200 Hz**

1. Fn26 establishes the second of three preset command frequencies. Used to configure a specific speed for multi-step applications.

### **Fn27 - SP3 Frequency**

**Factory Setting = 30 Hz; Range = 0.0 ~ 200 Hz**

1. Fn27 establishes the third of three preset command frequencies. Used to configure a specific speed for multi-step applications.

### **Fn28 : Reserved**

### **Fn29 - Software (program) version**

**- Factory Setting = 1.8**

### **Fn30 : Fault trace**

1. Keypad will indicate the sequence of the occurrence of faults by location of the decimal point:  
**x.xx** = the most recent fault  
**xx.x** = the previous fault  
**xxx.** = the earliest fault in the record
2. When entering the Fn30 function, the x.xx record will be displayed first. Pressing the  $\wedge$  button will read out **xx.x then xxx. then x.xx** consecutively.
3. When entering Fn30 function, if the RESET button is pressed, the fault record will be cleared. Indication display will show **-.-, --.- and ---.**
4. Example: When the content of fault memory indicates O.CC, the latest fault was OC-C (over current during constant speed).

## Chapter 4 - Fault Codes

### 4.1 - Failure or Trip which cannot be reset by Reset Key

FAULT CODE	CONTENT	PROBABLE CAUSE	WHAT TO DO
CPF	Program Error	High electronic noise	Install RC type suppressor on all contactor/brake coils
EPR	EEPROM error	EEPROM defective	Replace Drive
OV	Over voltage in stop mode	Detection circuit is damaged	Replace Drive
LV	Low voltage in stop mode	1. Input voltage too low 2. Detection circuit is damaged	1. Correct Input voltage 2. Replace Drive
OH	Heatsink overheat during stop mode	1. Ambient temperature is high or ventilation is poor 2. Detection circuit is damaged	1. Replace Drive 2. Improve Ventilation

## 4.2 - Failure or Trip which can be reset by Reset Key but cannot be Auto Reset

FAULT CODE	CONTENT	PROBABLE CAUSE	WHAT TO DO
OC	Over-current during stop mode	Detection circuit failure	Replace Drive
OL1	Motor over-load	1. Excessive load 2. Incorrect V/f pattern 3. Improper Fn18 setting	1. Select a larger HP unit 2. Select correct V/f pattern 3. Adjust Fn18 according to instructions
OL2	Drive over-load	1. Excessive load 2. Incorrect V/f pattern	1. Select a larger HP unit 2. Select correct V/f pattern

### 4.3 - Failure or Trip which can be Auto Reset or reset by Reset Key

FAULT CODE	CONTENT	PROBABLE CAUSE	WHAT TO DO
OCS	Over-current during start	1. Motor is shorted 2. Motor is grounded 3. Transistor module damaged	1. Inspect/repair motor 2. Remove grounding point 3. Replace Drive
OCA	Over-current during acceleration	1. Acceleration time setting too short 2. Wrong V/f pattern 3. Motor exceeds unit rating	1. Extend acceleration time 2. Select correct V/f pattern 3. Select larger HP unit
OCC	Over-current during constant speed	1. Transient loading 2. Input voltage fluctuations	1. Check load condition 2. Install a reactor between the power supply and the Drive
OCd	Over-current during deceleration	1. Deceleration setting too short	1. Extend deceleration time
OCb	Over-current during braking	DC braking frequency, braking voltage, or braking time setting too high	Reduce settings of Fn15, Fn16, or Fn17
OVC	Over-voltage during constant speed operation	1. Deceleration time is set too short or load inertia is too high 2. Input voltage fluctuations	1. Extend deceleration time 2. Correct line voltage problem
LVC	Low Voltage during constant speed	1. Input voltage too low 2. Input voltage fluctuations	1. Correct input voltage 2. Correct line voltage
OHC	Overheat during constant speed	1. Load is too great 2. Ambient temperature too high or poor ventilation	1. Check load 2. Limit ambient temperature or improve ventilation

## 4.4 - Operation Stop Indications

FAULT CODE	CONTENT	WHAT TO DO
SP0	Zero speed stop	An SP0 fault code can only occur when Fn7 is set to 0. If an SP0 fault code occurs and Fn11=0, use the keypad to increase the speed above 1 Hz. If an SPO fault code occurs and Fn11=1, increase the value of the external analog signal.
SP2	Keypad emergency stop	If Fn10 = 1 and the STOP key on the keypad is pressed during operation, the drive will stop according to the setting in Fn14 and stop. Keypad will flash E.S. after stop. (Refer to instruction for Fn19 for details.)
E.S.	External emergency stop	When the external emergency stop signal is activated via the multi-function input terminal, the drive will decelerate and stop. Keypad will flash E.S. after stop. (Refer to instruction for Fn19 for details.)
b.b.	External BASE BLOCK	When the external BASE BLOCK signal is activated via the multi-function terminal, the drive output will stop immediately and flash b.b. for indication. (Refer to instruction for Fn19 for details.)

## 4.5 - Operation Error Indications

FAULT CODE	CONTENT	PROBABLE CAUSE	WHAT TO DO
LOC	Motor direction locked	1. Attempted to reverse direction when Fn22 = 1 2. Attempted to set Fn22 to 1 when Fn04 = 1	1. Change Fn22 to 0 2. Change Fn04 to 0
ER1	Keypad operation error	1. Press UP or DOWN arrow keys when Fn11 = 1 or under SP1 operation 2. Attempted to change Fn29 3. Attempted to change parameter that cannot be changed during run mode. (Refer to parameter list)	1. Use UP or DOWN arrow keys to adjust frequency setting after changing Fn11 = 0 2. Do not change Fn29 3. Change function during stop mode
ER2	Parameter setting error	1. Fn6 < or = Fn7	1. Change so Fn6 > Fn7

---

**Chapter 5 - Other Information****5.1 - Selecting AC Line/Load Reactors**

Model	Reactor	
	Current Value ( A )	Inductance ( m H )
ME2-2P2-M	3.0	7.0
ME2-2P5-M	5.2	4.2
ME2-201-M	9.4	2.1
ME2-202-M	19.0	1.1
ME2-203-M	25.0	0.71

## 5.2 - Record of Settings

Customer				Model	
Application				Telephone	
Address					
Fn##	Value	Fn##	Value	Fn##	Value
Fn00		Fn11		Fn22	
Fn01		Fn12		Fn23	
Fn02		Fn13		Fn24	
Fn03		Fn14		Fn25	
Fn04		Fn15		Fn26	
Fn05		Fn16		Fn27	
Fn06		Fn17		Fn28	
Fn07		Fn18		Fn29	
Fn08		Fn19		Fn30	
Fn09		Fn20			
Fn10		Fn21			